

# PIGEON RB350-CM3

Pigeon RB350-CM3 is a computer designed for use in control and automation systems. Pigeon RB350-CM3 is powered by Raspberry Pi Compute Module 3 and Linux system.

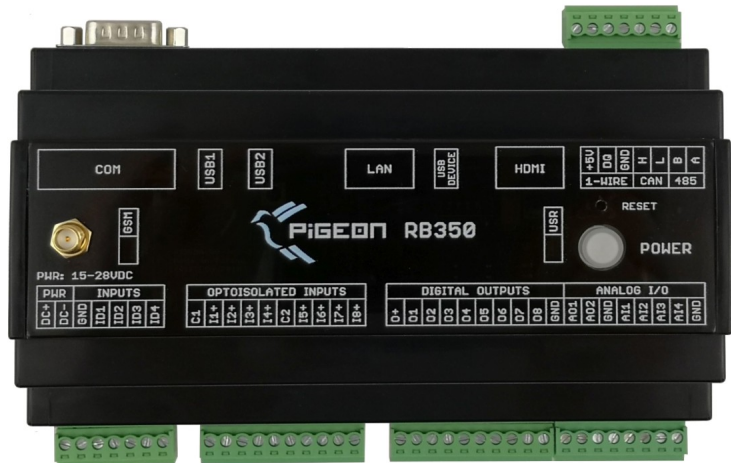

## FEATURES

### ■ Powered by Raspberry Pi CM

BCM2837 processor

1Gbyte RAM

4Gbyte eMMC Flash

### ■ A lot of inputs and outputs

8 x digital opto-isolated inputs

4 x dry contact inputs

8 x open drain outputs

4 x analog inputs 0-10V

2 x analog outputs 0-10V

### ■ Rich set of interfaces

2 x USB 2.0

CAN

1-Wire

RS-232

RS-485

Ethernet

HDMI

mPCIe for GPRS/EDGE/3G/LTE modules

### ■ Real Time Clock

Real Time Clock with supercapacitor backup

### ■ Robust design

Two watchdogs

Meets requirements of EN 61326-1:2013 for basic and industrial electromagnetic environments

### ■ Created for long life

Designed, developed and produced in European Union

No moving parts

### ■ Designed for low power consumption

High efficiency DC/DC converters

Peripherals power supply control

### ■ Integrated UPS

Supercapacitor based UPS for reliable operation

Safe shut down procedure

Power button

### ■ Linux on board

Small and stable distribution that is fully compatible with official Raspberry Pi OS

Full support for all interfaces

### ■ Easy programmable

There are a lot of programming languages which can be used to program Pigeon: C/C++, Python, Java

Open source and commercial software for automation and control systems

### ■ DIN rail enclosure

DIN rail enclosure with optional wall mount bracket

## APPLICATIONS

### ■ Control and automation systems

### ■ Home automation

### ■ Building management systems

### ■ Process control

### ■ Industrial automation

### ■ Machine control

### ■ Industrial control networks

### ■ Monitoring

## 1. TECHNICAL SPECIFICATIONS

CPU & memory		
SoC	BCM2837, ARM Cortex A53 core, 1.2GHz*	
RAM memory	1 Gbyte	
Flash memory	4Gbyte eMMC	
Power supply		
Supply voltage	15 ... 28V DC	
Power consumption	Conditions	Supply current @ 24V
	CPU 100% load, Ethernet 100Mbit active	210 mA
	CPU 1% load, Ethernet no active	75 mA
Interfaces		
Ethernet	1 x Ethernet 10/100-Mbit, Auto MDI-MDIX, RJ-45	
CAN	1 x CAN, MCP2515, terminal blocks	
1-WIRE	1 x 1-WIRE, DS2482S-100+, terminal blocks	
RS-232	1 x RS-232 (RXD, TXD, RTS, CTS), DB9 male	
RS-485	1 x RS-485, terminal blocks	
USB	2 x USB host 2.0 Type-A, 1 x Mini USB 2.0 Type B	
PCI Express Mini Card	1 x mPCIe with USB 2.0 and Mini-SIM card support, cable U.FL to SMA female connector for external antenna	
Inputs & Outputs		
Digital opto-isolated inputs	Channels	8
	Low-level input voltage	0 ... +5 V DC
	High-level input voltage	+10 ... +28V DC
	Isolation voltage	5 kV <sub>RMS</sub>
	Input resistance	>=10kΩ
Dry contact inputs	Channels	4
Open drain outputs	Channels	8
	Maximum current	500 mA
	Maximum voltage	28 V DC
Analog inputs	Channels	4
	Voltage Range	0 ... +10V
	Resolution	10-bit
Analog outputs	Channels	2
	Voltage Range	0 ... +10V
	Resolution	10-bit
5V output DC	Total maximum current	1 A
	Note: Total maximum current is the current of +5V DC connector output and all USB +5V outputs	
Terminal blocks	Wire range	0.5 - 1.5 mm <sup>2</sup> , 28 -16 AWG
	Torque	0.2 Nm
	Strip length	7 mm
Standards		
EU standard	EN 61326-1:2013	

\* depending on processor workload, CPU throttling may occur.

Environment		
EMC	EN 55011 group 1 class A, EN 55011 group 1 class B	
Operating Temperature	0 °C ~ 50 °C	
Operating Relative Humidity	5 ~ 95%, non-condensing	
Storage Temperature	-25 °C ~ 50 °C	
Protection Rating	IP20	
Miscellaneous		
Watchdog	Two watchdogs: WDT 1: SoC BCM2835 built-in WDT 2: connected to GPIO	
RTC buffer time	min. 24h	
Dimension	158 x 114 x 59 mm (including terminal blocks connectors)	
Enclosure	Mount	Din-rail, wall mount
	Material	ABS UL-94-HB
Weight	325g	

## 2. CONNECTIONS

### 2.1. POWER SUPPLY AND DRY CONTACT INPUTS

Fig. 1 shows power supply and dry contact inputs connections.

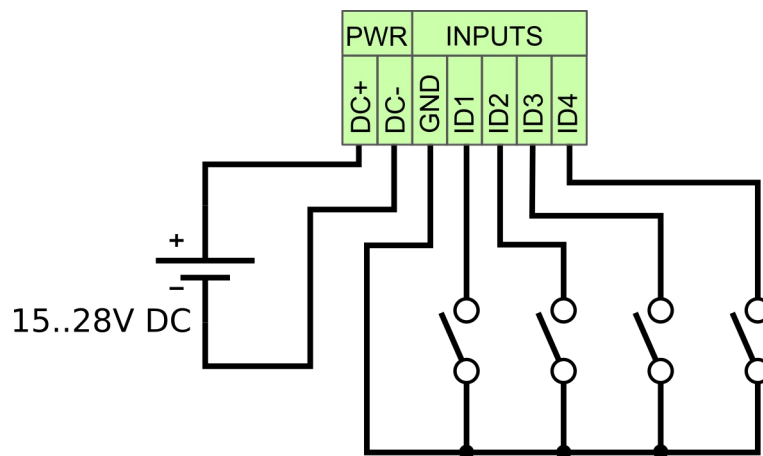

Fig. 1. Power supply and dry contact inputs connections

Recommended power supply: DELTA DRC-24V30W1A (24V 1,25 A).

### 2.2. DIGITAL OPTO-ISOLATED INPUTS

Fig. 2 shows digital opto-isolated inputs connections.

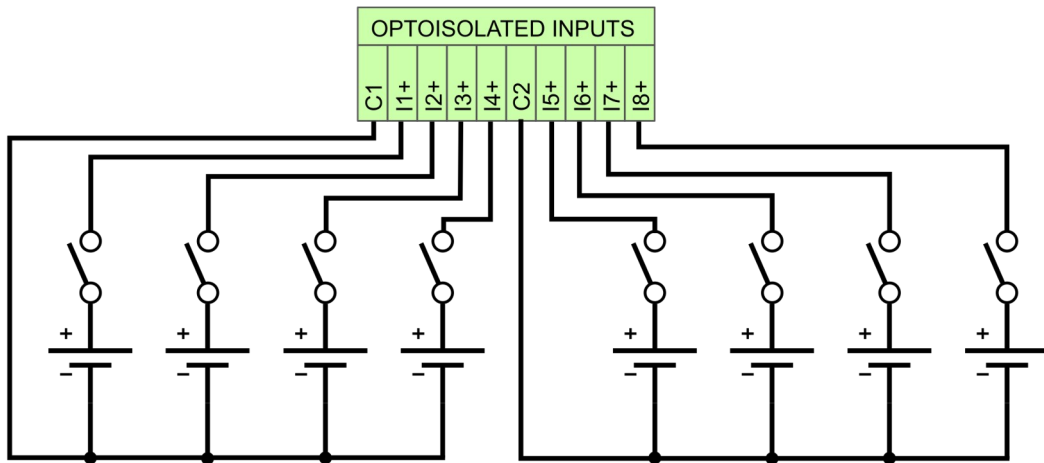

Fig. 2. Digital opto-isolated inputs connections

### 2.3. OPEN DRAIN OUTPUTS

Recommended connection of LED (a) and relays (b,c) to open drain outputs is shown on fig. 3. O+ is terminal to connect + potential when switching inductive load. The internal diodes protect the output transistors from transient voltage peaks (b). In case of long cables to relay, connection with external diode (c) is recommended.

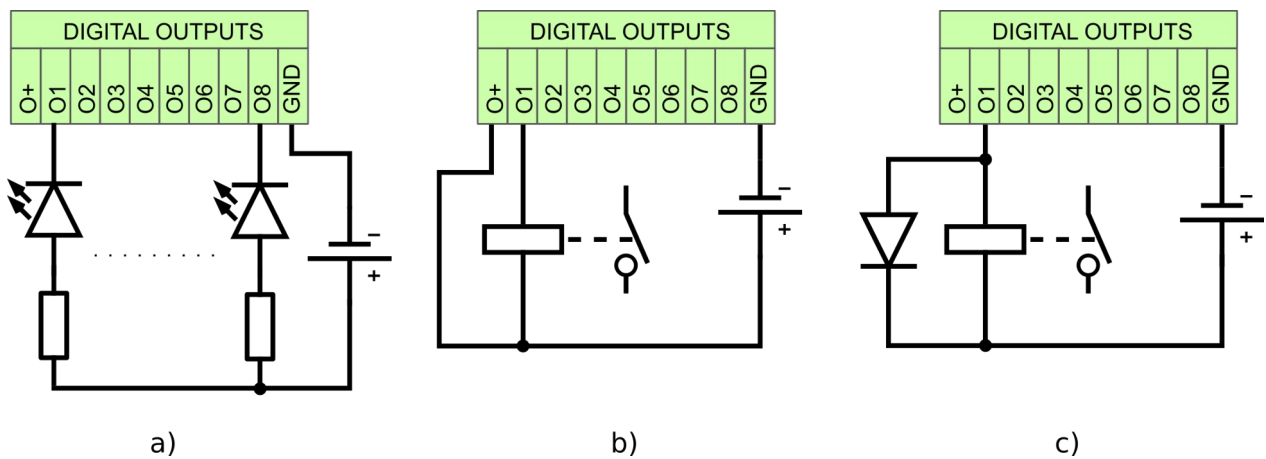

Fig. 3. Example digital outputs connections: (a) LED, (b,c) relay

### 2.4. ANALOG INPUTS AND OUTPUTS

Fig. 4 shows analog inputs and outputs connections.

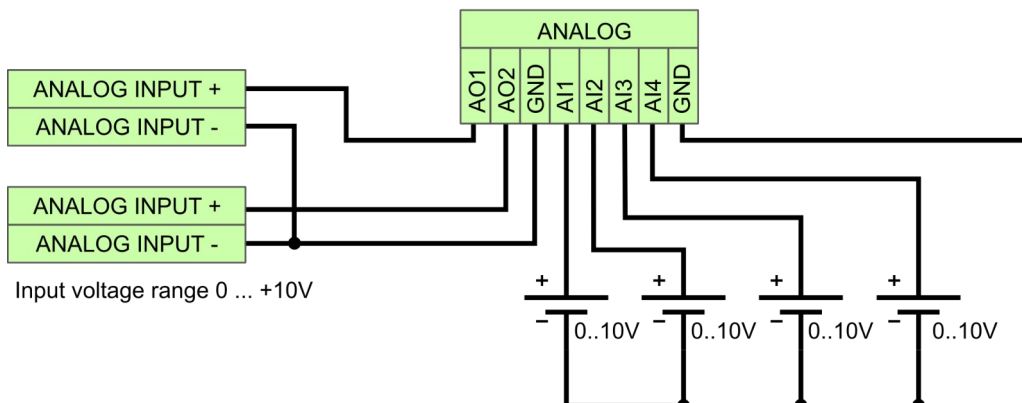

Fig. 4. Analog inputs and outputs connections

## 2.5. CABLE LENGTH

Connector	Maximum cable length
Power supply	3 m
USB	3 m
HDMI	3 m
1-wire	3 m
Analog inputs/outputs	3 m
Digital inputs/outputs	3 m
RS-232	3 m
Ethernet 10/100Mbit	30 m
CAN	30 m
RS-485	30 m

## 3. DIMENSIONS

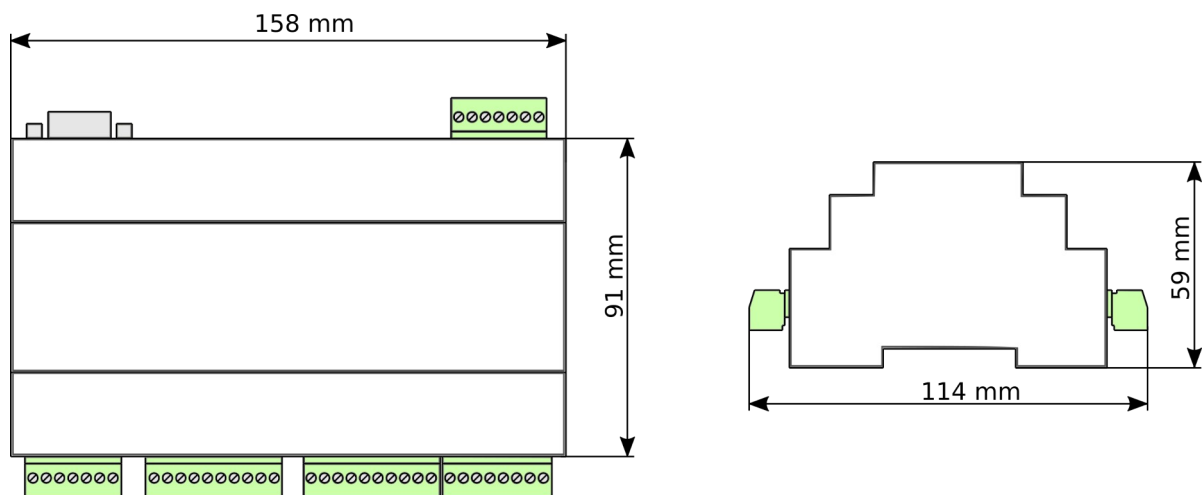

Fig. 5. RB350-CM3 dimensions

## 4. ENVIRONMENTAL PROTECTION



This marking on the product, accessories or literature indicates that the product and its electronic accessories should not be disposed of with other household waste. To prevent possible harm to the environment please separate these items from other types of waste and recycle them responsibly to promote the sustainable reuse of material resources.

## 5. ORDER CODES

We offer customization of this product. Rebranding and hardware customization are possible. For available options or for further information on any aspect of this device, please contact KRISTECH.

Order codes	Descriptions
RB350-CM3	Standard version
RB350-CM3-c-F-x	Front panel customized: c – customer code, x – front panel version
RB350-CM3-c-F-x-L-y	Front panel and label customized: c – customer code, x – front panel version, y – label version

## 6. SAFETY INSTRUCTIONS

Before you work on any equipment, be aware of the hazards involved with electrical circuitry, and be familiar with standard practices for preventing accidents.

Only qualified personnel should be allowed to install, replace, or service this equipment.

We cannot guarantee that no accidents or damage will occur due to improper use of the device. Please use this product with care and operate at your own risk.

Any external power supply used with PIGEON RB350-CM3 shall comply with relevant regulations and standards applicable in the country of intended use.

This product is intended to be installed indoors. Keep this product away from water, fire, humidity or hot environments.

PIGEON RB350-CM3 is not authorized for use in safety-critical applications.

In the case of device failure, please disconnect it from power.

All devices used with this product should comply with relevant standards for the country of use and be marked accordingly to ensure that safety and performance requirements are met.

Take care whilst handling to avoid mechanical or electrical damage to the printed circuit board and connectors.

To prevent electrostatic discharge (ESD) from damaging the system, be aware of the precautions to consider when setting up the system or handling parts. In particular, when installing devices in M.2 slots. A discharge of static electricity from a finger or other conductor may damage system boards or other static-sensitive devices.



For more information, please visit:

<http://pigeoncomputers.com/products/pigeon-rb350-cm3/>

The information in this document is subject to change without notice. Errors excepted

Copyright © Kristech. 2018. All rights reserved

ARM is registered trademark and ARM Limited

Linux is a registered trademark of Linus Torvalds

Raspberry Pi is a trademark of the Raspberry Pi Foundation

All other brand names or product names are the property of their respective holders