

# PIGEON RB100-CM3

Pigeon RB100-CM3 is a computer designed for use in control and automation systems. Pigeon RB100-CM3 is powered by Raspberry Pi Compute Module 3 and Linux system.

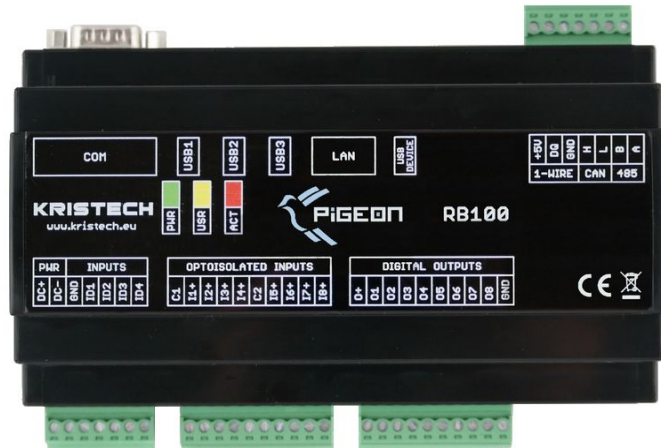

## FEATURES

### ■ Powered by Raspberry Pi CM

BCM2837 processor

1Gbyte RAM

4Gbyte eMMC Flash

### ■ A lot of inputs and outputs

8 x digital opto-isolated inputs

4 x dry contact inputs

8 x open drain outputs

### ■ Rich set of interfaces

3 x USB 2.0

CAN

1-Wire

RS-232

RS-485

Ethernet

### ■ Real Time Clock

Real Time Clock with battery backup

### ■ Robust design

Two watchdogs

Meets requirements of EN 61326-1:2013 for basic and industrial electromagnetic environments

### ■ Created for long life

Designed, developed and produced in European Union

No moving parts

No electrolytic capacitors

### ■ Designed for low power consumption

High efficiency DC/DC converters

Peripherals power supply control

### ■ Linux on board

Small and stable distribution that is fully compatible with official Raspberry Pi OS

Full support for all interfaces

### ■ Easy programmable

There are a lot of programming languages which can be used to program Pigeon: C/C++, Python, Java

Open source and commercial software for automation and control systems

### ■ DIN rail enclosure

DIN rail enclosure with optional wall mount bracket

## APPLICATIONS

### ■ Control and automation systems

### ■ Home automation

### ■ Building management systems

### ■ Process control

### ■ Industrial automation

### ■ Machine control

### ■ Industrial control networks

### ■ Monitoring

## 1. TECHNICAL SPECIFICATIONS

CPU & memory		
SoC	BCM2837, ARM Cortex A53 core, 1.2GHz*	
RAM memory	1 Gbyte	
Flash memory	4Gbyte eMMC	
Power supply		
Supply voltage	8 ... 28V DC	
Power consumption	Conditions	Supply current @ 12V
	CPU 100% load, Ethernet 100Mbit active	435 mA
	CPU 1% load, Ethernet no active	120 mA
Interfaces		
Ethernet	1 x Ethernet 10/100-Mbit, Auto MDI-MDIX, RJ-45	
CAN	1 x CAN, MCP2515, terminal blocks	
1-WIRE	1 x 1-WIRE, DS2482S-100+, terminal blocks	
RS-232	1 x RS-232 (RXD, TXD, RTS, CTS), DB9 male	
RS-485	1 x RS-485, terminal blocks	
USB	3 x USB host 2.0 Type-A, 1 x USB device 2.0 Type-A	
Inputs & Outputs		
Digital opto-isolated inputs	Channels	8
	Low-level input voltage	0 ... +5 V DC
	High-level input voltage	+10 ... +28V DC
	Isolation voltage	5 kV <sub>RMS</sub>
	Input resistance	>=10kΩ
Dry contact inputs	Channels	4
Open drain outputs	Channels	8
	Maximum current	500 mA
	Maximum voltage	28 V DC
5V output DC	Total maximum current	1 A
	Note: Total maximum current is the current of +5V DC connector output and all USB +5V outputs	
Terminal blocks	Wire range	0.5 - 1.5 mm <sup>2</sup> , 28 -16 AWG
	Torque	0.2 Nm
	Strip length	7 mm
Standards		
EU standard	EN 61326-1:2013	
Environment		
EMC	EN 55011 group 1 class A, EN 55011 group 1 class B	
Operating Temperature	0 °C ~ 50 °C	
Operating Relative Humidity	5 ~ 95%, non-condensing	
Storage Temperature	-25 °C ~ 50 °C	
Protection Rating	IP20	

\* depending on processor workload, CPU throttling may occur

Miscellaneous		
Watchdog	Two watchdogs: WDT 1: SoC BCM2835 built-in WDT 2: connected to GPIO	
RTC backup battery	CR2032, 3V	
Dimension	158 x 114 x 59 mm (including connectors)	
Enclosure	Mount	Din-rail, wall mount
	Material	ABS UL-94-HB
Weight	260g	

## 2. CONNECTIONS

### 2.1. POWER SUPPLY AND DRY CONTACT INPUTS

Fig. 1 shows power supply and dry contact inputs connections.

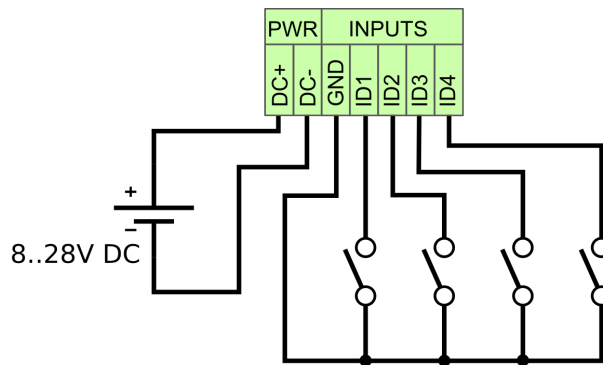

Fig. 1. Power supply and dry contact inputs connections

Recommended power supply: DELTA DRC-24V30W1A (24V 1,25 A).

### 2.2. DIGITAL OPTO-ISOLATED INPUTS

Fig. 2 shows digital opto-isolated inputs connections.

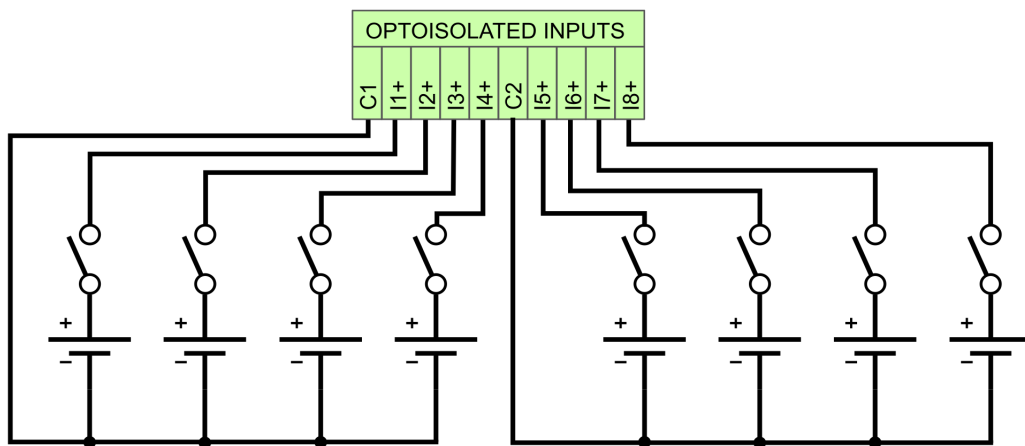

Fig. 2. Digital opto-isolated inputs connections

### 2.3. OPEN DRAIN OUTPUTS

Recommended connection of LED (a) and relays (b,c) to open drain outputs is shown on fig. 3. O+ is terminal to connect + potential when switching inductive load. The internal diodes protect the output transistors from transient voltage peaks (b). In case of long cables to relay, connection with external diode (c) is recommended.

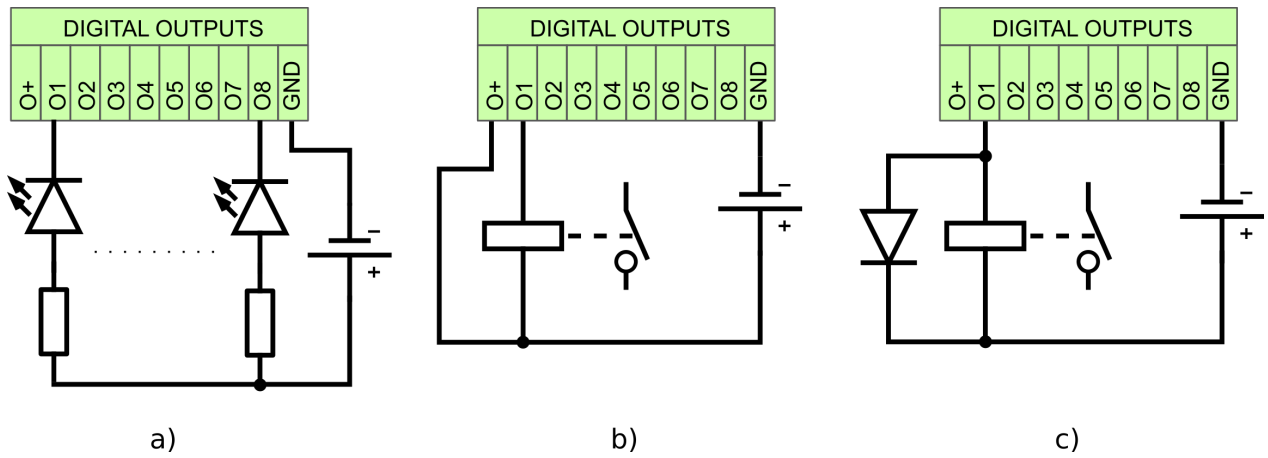

Fig. 3. Example digital outputs connections: (a) LED, (b,c) relay

### 2.4. CABLE LENGTH

Connector	Maximum cable length
Power supply	3 m
USB	3 m
1-wire	3 m
Digital inputs/outputs	3 m
RS-232	3 m
Ethernet 10/100Mbit	30 m
CAN	30 m
RS-485	30 m

### 3. DIMENSIONS

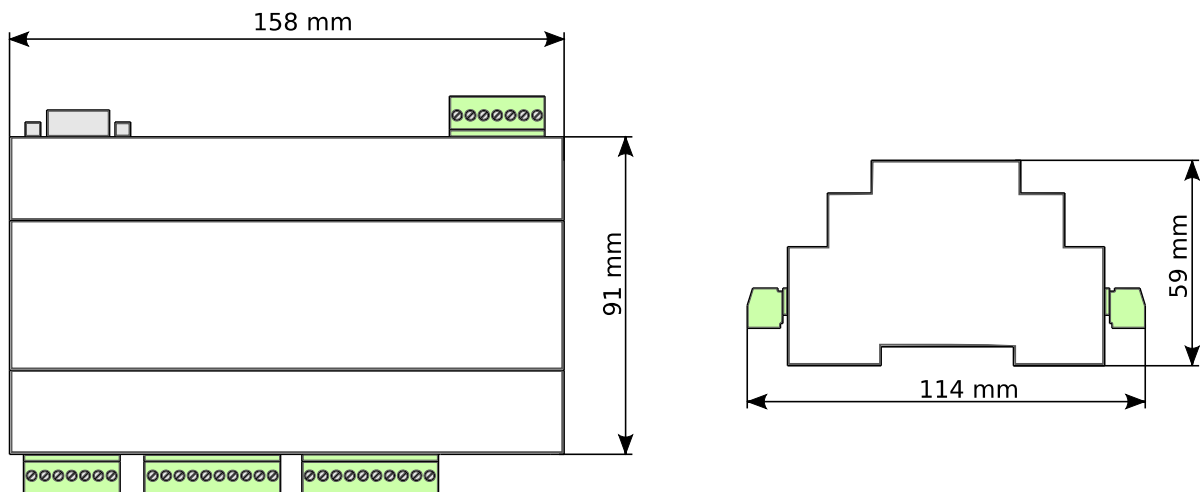

Fig. 4. RB100-CM3 dimensions

## 4. ENVIRONMENTAL PROTECTION



This marking on the product, accessories or literature indicates that the product and its electronic accessories should not be disposed of with other household waste. To prevent possible harm to the environment please separate these items from other types of waste and recycle them responsibly to promote the sustainable reuse of material resources.

## 5. ORDER CODES

We offer customization of this product. Rebranding and hardware customization are possible. For available options or for further information on any aspect of this device, please contact KRISTECH.

Order codes	Descriptions
RB100-CM3	Standard version
RB100-CM3-c-F-x	Front panel customized: c – customer code, x – front panel version
RB100-CM3-c-F-x-L-y	Front panel and label customized: c – customer code, x – front panel version, y – label version



For more information, please visit:

<http://pigeoncomputers.com/products/pigeon-rb100-cm3/>

Pigeon RB100-CM3 is not authorized for use in safety-critical applications  
 The information in this document is subject to change without notice. Errors excepted  
 Copyright © Kristech. 2015. All rights reserved  
 ARM is registered trademark and ARM Limited  
 Linux is a registered trademark of Linus Torvalds  
 Raspberry Pi is a trademark of the Raspberry Pi Foundation  
 All other brand names or product names are the property of their respective holders